

# WATERPROOF GT 53-26 PEL

Waterproof polypropylene tool case



## General features

- waterproof and airtight
- interstackable
- corrosionproof, sandproof and dustproof
- shockproof and crushproof
- temperature rating -33°C/+90°C
- ergonomic handle, rubber coated grip
- jam free latches with user-friendly opening mechanism
- corrosion proof metal hinges with lid stay features
- pressure release valve
- special PU injected seal
- stainless steel reinforced pad lockable points providing maximum security

## Internal Configuration

- document wallet
- 2 tool pallets with elastics
- 1 tool pallet with elastics (double side)
- bottom tray with removable dividers
- wheels and telescopic handle
- equipped with gas-pressurised lid supports

## Versions

- WATERPROOF GT 42-09 PEL
- WATERPROOF GT 42-09 PTS
- WATERPROOF GT 42-16 PEL
- WATERPROOF GT 42-16 PTS
- WATERPROOF GT 44-19 PEL
- WATERPROOF GT 44-19 PSS
- WATERPROOF GT 44-19 PTS
- WATERPROOF GT 52-21 PEL
- WATERPROOF GT 52-21 PSS
- WATERPROOF GT 52-21 PTS
- WATERPROOF GT 53-26 PEL
- WATERPROOF GT 53-26 PTS
- WATERPROOF GT 58-23

## EAN

8024482180809



Technical features	A	B	C	D	E
mm internal dimensions	538	405	250	60	190
	Weight Kg 12,00				
inc internal dimensions	21 3/16	15 15/16	9 13/16	2 3/8	7 1/2
	Weight lbs 26.45				

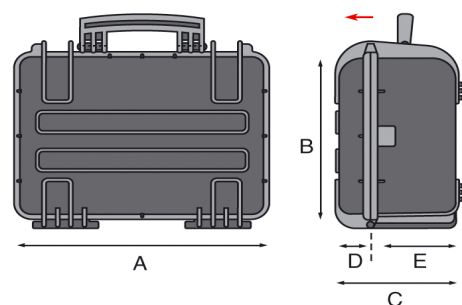

## **WATERPROOF GT 53-26 PEL**

Waterproof polypropylene tool case



Watertight and perfectly sealed thanks to the exclusive neoprene "O" ring and to the purge valve, these cases grant an absolute protection to your tools. Made of resistant lightweight resin, they are provided with strong locks and a useful and ergonomic handle. They are ideal for use in the harshest environment, such as industrial, aeronautical, military and nautical fields.

# Accessories

WATERPROOF GT 53-26 PEL



EXPL COMBILOCK



EXPL PADLOCK



WL01



WL02



WL03



WL04



WL05



EXPL TSA.DIGILOCK



UNIVERS.TROLLEY